

# Humidification Strategies for Data Centers and Network Rooms

## White Paper 58

Revision 2

by Tony Evans

### > Executive summary

The control of humidity in Information Technology environments is essential to achieving high availability. This paper explains how humidity affects equipment and why humidity control is required. Quantitative design guidelines for existing and new computing installations are discussed. Alternative methods to achieve desired humidity are described and contrasted. The difficult issue of how and where humidity should be measured is explained. The hidden costs associated with over-humidification are described.

### Contents

*Click on a section to jump to it*

Introduction	2
The nature of humidity in the IT environment	2
IT equipment and environment humidity guidelines	4
Humidity measure	5
Humidity control	6
Real-world examples of cost minimization	9
Conclusion	11
Resources	12
Appendix	13

## Introduction

Every piece of data center equipment and every human on earth is engulfed by an ocean of air. This fact is taken for granted to be good for humans, but under certain circumstances the air surrounding IT equipment can be harmful to internal electronic components and lead to failure and downtime. The water vapor contained in air protects IT equipment from dangerous static electrical discharge. Reliance on precision cooling solutions to maintain the proper humidity level in a computer room or data center does not always assure proper humidity levels at the IT equipment air intake. This paper explains the nature of humidity, its effects and its management in computer rooms and data centers. Educated IT professionals can leverage knowledge about data center humidification to increase equipment availability and reduce operational costs.

## The nature of humidity in the IT environment

Air is made up of a combination of gasses which include nitrogen (78%), oxygen (21%), carbon dioxide (0.3%), and water vapor. The water vapor in air is known as humidity. Air in the IT environment containing the proper amount of water vapor plays an important role in maximizing the availability of computing equipment. Air containing too much or too little water vapor directly contributes to reduced productivity and equipment downtime.

### How humidity is quantified

The amount of water normally contained in air is actually very small. One pound of normal data center air (air can be weighed) occupies about 13.6 cubic feet (.385 m<sup>3</sup>) of space and contains about 1/7th of an ounce (4.22 ml) of water. As an example, the air inside a small data center measuring 30 feet by 20 feet (9.1 by 6.09 meters) and having a 10-foot (3.04 meters) ceiling will contain just over 63 ounces (1863 ml) of water vapor under normal conditions. The amount of water that can be contained in this volume of air, however, is not fixed. As air temperature increases the air has the ability to hold more and more water vapor. As air temperature decreases, the air's ability to hold water decreases.

IT professionals should familiarize themselves with two key terms. The first term, *relative humidity* (also known as RH), is always expressed as a percentage from 0% to 100% and represents the percentage of water vapor in the air relative to the maximum amount of water vapor the air can hold at a given temperature. For example, if the temperature in the small data center described in the previous paragraph above were 73°F (22.7 °C), the 63 ounces (1863 ml) of water vapor contained in the air would equate to a relative humidity of 50%. If the relative humidity is zero, then no water vapor present. If the relative humidity is 100%, then the air is holding all the water vapor it possibly can.

The second term, *dew point*, is always expressed as a temperature. Dew point is the temperature at which water vapor leaves the air and appears on objects as liquid water. For example, when an aluminum can containing a cold liquid is left outside on a warm summer day, droplets of liquid water form on the can. This happens because the cold drink cools the surrounding air to a temperature lower than the air's dew point. The air has more water vapor than it can hold at its new lower temperature and the extra water vapor leaves the air as liquid water droplets on the can. In our small data center example above any object (including IT equipment) that cools the surrounding air to a temperature below about 54°F (12.2 °C) will cause liquid water to condense upon it.

Relative humidity and dew point are related terms. In fact, the dew point for air at a given temperature will rise as the air's relative humidity increases. When air reaches 100% relative humidity the air's dew point is always equal to its temperature and the air is considered *saturated*.

## Effects of humidity in the IT environment

Humidity in the computer room or data center provides beneficial effects when it is maintained at proper levels and potential problems when it is at a level that's too high or too low. The primary benefit in maintaining proper humidity levels is a reduction in the "charging" effect that can lead to static electrical discharge by making the air itself just a little more electrically conductive and the surfaces it touches just slightly "wet". Because of the air's slight increase in conductivity, the imbalance of positive and negative charges that create static electricity are less likely to result in electrical discharges (10,000+ volt sparks) that can damage computing equipment<sup>1</sup>. The cool, low humidity air moving throughout the data center can potentially be a source of static electricity. Every time this cool air moves across an ungrounded insulated surface proper humidity levels must be maintained. The effects of varied relative humidity levels on everyday activities that generate static electricity are shown in **Table 1** below.

**Table 1**

Comparison of static electrical buildups at different relative humidity levels

Action	Static buildup at 80%	Static buildup at 20% RH
Walking across ungrounded raised floor tile	250 Volts	12,000 Volts
Walking across synthetic carpet	1,500 Volts	35,000 Volts

The values of 250 and 1500 volts of static electricity pose no real threats to computing equipment. The 12,000 and 35,000-volt values can discharge as sparks and can cause damage. High relative humidity levels in the IT environment further reduce the chance of static discharge but are not desirable due to the increased likelihood of corrosion of metal components. High humidity levels can also increase the risk of water damage to equipment. This is why most IT equipment specifications show the acceptable humidity range in terms of *non-condensing humidity*.

In essence, equipment manufacturers are stating that their equipment will operate normally within a humidity range (typically 20-80% RH) as long as the temperature of the equipment itself and everything around it remains above the dew point temperature. This is the temperature at which water vapor in the air starts condensing on the equipment just like in the formerly described cold aluminum can example. Environments with high relative humidity and rapid changes in temperature are most likely to experience condensing humidity. When upper humidity limits are exceeded in IT environments with high-speed printing, paper stock may swell and increase its thickness resulting in jams and process downtime.

## Why we lose and gain humidity in the IT environment

*Infiltration, condensation* and *ventilation* cause changes in IT environment humidity. Humidifiers add water vapor and dehumidifiers remove the water vapor. Together they maintain the IT environment humidity.

<sup>1</sup> The assertion that reduced static electrical charging occurs as relative humidity rises is being challenged by recent research. This research concludes that the same amount of charging occurs under all conditions, and it's the insulating layer of water molecules that forms on surfaces as relative humidity increases keeps static electrical discharges from occurring. This does not support the data shown in **Table 1**. However, in each case it's agreed that increased moisture content in air restricts static electrical discharge.

**Infiltration** - If we could place a high humidity body of air next to low humidity body of air, the two would quickly equalize to a humidity level between the high and low levels. When computer rooms are at different humidity levels than the outdoor or office space air that surrounds them, the humidity levels constantly try to equalize between the spaces. Obviously, the walls, floor, and ceiling surrounding the IT environment should stop this equalization but in many cases they do not. Water vapor can escape or enter through any porous surface or microscopic crack and change IT environment relative humidity.

The rate of humidity gain or loss due to infiltration is dependent upon the amount of open area and difference in humidity and temperature between the spaces. For example, let's assume the small data center described on Page 3 (73°F or 22.7 °C, 50%RH) was in a location where the outside weather was 35°F (1.66 °C) and 30% RH. If we open a normal-sized door (an emergency exit door for example) between the room and the outdoor environment, the room's RH would drop below 50% almost immediately. In less than 12 minutes the room would be below the minimum recommended RH of 40% (assuming no supplemental humidification in the room). If the data center had supplemental humidification we would lose 6.1lbs (2.76 kg) of water for each hour the door was left open. Infiltration problems require extra equipment to regulate humidity levels and in severe cases regulation may be impossible.

**Condensation** - Under some conditions the process of cooling IT environment air can remove large amounts of water vapor resulting in low relative humidity levels. This occurs when warm data center air is drawn through the cooling coil in a computer room air conditioner or air handler. Most cooling coils are maintained at a constant temperature of 43-48°F (6.1-8.8 °C). This is usually below the dew point of the air in the IT environment so just as in the example of water droplets forming on the cold aluminum can, water droplets can form on the cold cooling coil.

Very large volumes of air (over 160 cubic feet / 4.5 m<sup>3</sup> per minute for each kW of computing equipment) flow through the cooling coil at high velocity. In instances where the air stays in contact with the cooling coil long enough to be cooled below its dew point, liquid water called *condensate* forms on the cooling coil. Pumps inside the cooling equipment transport condensate away from the IT environment and into the building drainage system. Humidifiers are used to add needed water vapor back into the air stream exiting the cooling equipment. Humidifiers are a very common option found in computer room air conditioners and air handlers and are discussed in the "humidity control" section of this paper.

**Ventilation** - Fresh outdoor air must be continually introduced into all buildings to supply oxygen to the people inside. Fresh air supplied into computer rooms and data centers is called "make-up air" and affects relative humidity levels. The amount of fresh air required is determined when the room is designed and calculated by considering the room's specific use, the number of people that may occupy the room and the laws in effect at the time of construction. Changes in IT environment humidity due to ventilation issues vary widely based on the amount of outside air introduced into the room and the geography the building is located in. Ventilation air introduced in cold, dry climates or desert regions usually reduces humidity. Ventilation air introduced in warmer climates or during periods of rain adds humidity. The amount of air required for ventilation is usually a known quantity and is planned for during the cooling solution's specification. Ventilation discussed in more detail further on in this paper.

Humidity guidelines for computing equipment are published by most equipment manufacturers. Guidelines for data centers and computer rooms are published by ASHRAE (American Society of Heating, Refrigerating, and Air-Conditioning Engineers). Typical guidelines are provided in **Table 2**.

## IT equipment and environment humidity guidelines

**Table 2**

Humidity guidelines for IT equipment, computer rooms and data centers

Equipment or room type	Allowable RH range	Recommended RH range	Maximum dew point
Typical IT equipment	20% - 80%	Check product literature	Not applicable
Wiring closets	20% - 80%	40% - 55%	70° F (21.1° C)
Computer rooms and data centers	20% - 80%	40% - 55%	63° F (17.2° C)

Maximum dew point temperatures are provided to establish criteria to reduce the chances of condensing humidity when the IT environment is subject to rapid temperature change.

## Humidity measure

The single most important place to maintain proper relative humidity *is at the cooling air intake opening on IT equipment*. The acceptable temperature and humidity ranges for equipment published by IT manufacturers are based on readings at the point of air intake. Most pieces of computing equipment locate the cooling air intake in the front and the exit in the back as shown in **Figure 1**. Note the exhaust air exiting the server has a higher temperature and lower humidity but the dew point is unchanged. This is because the nature of the heat a server generates raises the temperature of the cooling air but does not change the amount of moisture in the air. The concept of using a single dew point setting for data center humidity control is discussed later in this paper.

Measurement of humidity levels at the IT equipment cooling air exhaust location is not required and has no effect on equipment availability. Since measurement at every piece of equipment is not normally possible, in environments that use rack enclosures it is minimally acceptable to monitor humidity inside the front door of the enclosure adjacent to the computing equipment itself in the top 1/3 of the rack enclosure. This is the elevation where damaging low humidity conditions at the equipment air intake are most likely to occur. This is also an ideal location to monitor air intake temperature as shown in **Figure 1**. Prior to measurement, ensure blanking panels are installed where necessary and back-to-front airflow in the rack is minimized. See White Paper 44, *Improving Cooling Performance Using Blanking Panels* for detailed recommendations.

 Related resource  
**White Paper 44**  
*Improving Cooling Performance Using Blanking Panels*

**Figure 1**  
 Server airflow and rack enclosure measuring point

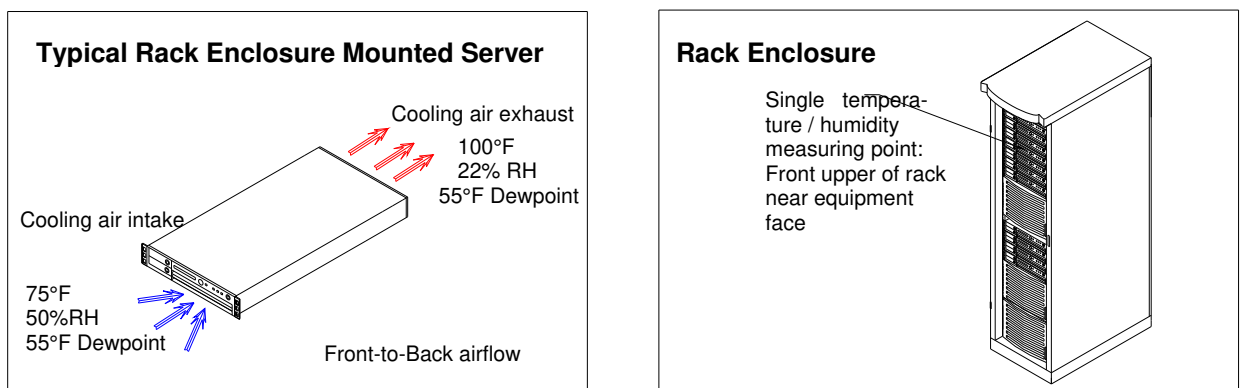

Use a temperature-humidity probe that interfaces with currently used operating and control systems to monitor and provide proactive warning of out-of-range humidity conditions (**Figure 2**). Many hand-held monitoring devices available allow for spot-checking of temperature and relative humidity anywhere in the room.

**Figure 2**

*Typical air temperature and humidity measuring device*



Most computer room air conditioners and air handlers measure the humidity level of data center air as it returns into the unit from the IT environment. **Figure 3** shows the monitoring points on a down flow unit. This data is used to control the operation of humidifiers if they are installed within the unit. The standard user interface on most precision cooling units provides readout of the relative humidity when requested.

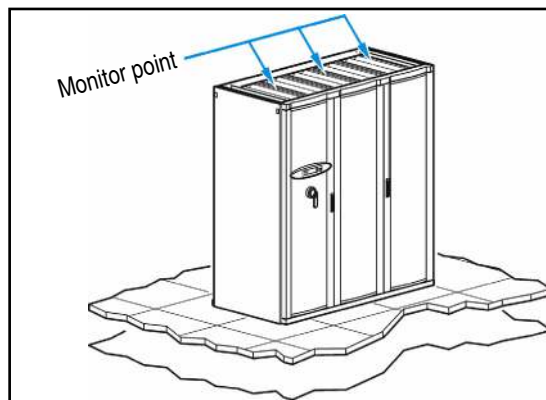

**Figure 3**

*Cooling system return air humidity monitoring*

## Humidity control

The best way to control humidity in the IT environment is to minimize the variables that cause humidity levels to change and maximize the performance of the systems designed to regulate humidity.

### Minimizing factors external to the IT environment that affect humidity

Minimizing infiltration protects the IT environment from those chronic humidity control problems that become acute when the outside weather changes. Use *vapor barriers* in the construction or renovation of computer rooms and data centers to control infiltration. A vapor barrier is a special non-porous sheet, paint, caulk, or other construction material applied to the walls, ceiling, and floor of the room. It surrounds the IT environment and minimizes humidity gain or loss from outside the room.

Fewer people work in data centers compared to normal office spaces. For this reason the quantity of outside air used for ventilation purposes is usually small and should be planned for by cooling professionals when designing the room. Office space that is converted into a computer room and still retains the building air conditioning system for ventilation purposes creates unique challenges and benefits. The benefit is that the outdoor air required for ventilation is already processed by the building climate control system to a moderate temperature and humidity level before it enters the computer room.

The challenge is to ensure that the normal office space air (the office now having been converted into a computer room) does not conflict with the operation of the room's additional precision cooling equipment. For example if the volume of air entering the room from the building ventilation system is warmer or at a different relative humidity than the desired setting on the computer room air conditioner, a portion of the air conditioner's capacity will be used to cool or change the humidity of the air as necessary. Computer rooms with temperature and humidity problems that utilize both building and precision cooling systems require detailed analysis to diagnose and optimize. A cooling professional is best suited to assist with problems of this type.

### Minimizing factors internal to the IT environment that affect humidity

Humidifiers are used to increase the moisture content of air. They exist in virtually all data centers and in some cases are almost continuously used. They are commonly installed in precision cooling systems but may also act as stand-alone central systems. Humidifiers installed inside computer room air conditioners replace water lost to condensation before the air exits the cooling unit.

Water vapor supplied by central humidification systems has to migrate across the IT environment. This equalization process happens quickly and in most cases the cooling air is acceptably humidified prior to its entry into the IT equipment. In environments with limited hot / cold air mixing or fully ducted air supply or return systems, condensation within cooling units is very limited or eliminated all together. In this case humidifiers in the individual cooling units can be minimized or eliminated resulting in lower capital, operational, and maintenance costs. Proper air management practices favor the use of central humidification.

Three types of humidification systems are commonly installed in computer room air conditioners and air handlers:

- *Steam canister* humidifiers introduce liquid water into a canister containing electrodes. When the electrodes are powered, water is boiled and steam (water vapor) is produced. The steam is introduced via a tube into the air stream to be humidified.
- *Infrared* humidifiers suspend quartz lamps over an open pool of water. The effect of the intense infrared light on the surface of the water is the release of water vapor that migrates into the air stream requiring humidification.
- *Ultrasonic* humidifiers rapidly vibrate water to create a fog or mist that is introduced into the air stream requiring humidification.

All three designs effectively humidify the IT environment. Steam canister and infrared humidifiers consume more electrical energy than ultrasonic humidifiers. Ultrasonic humidifiers are more expensive to buy because they require a reverse-osmosis water purification system to supply water (smaller systems can sometimes use de-ionized water). All three types of systems require maintenance. Steam canisters must be cleaned or replaced and infrared systems require cleaning and bulb replacement. Ultrasonic systems require transducer replacement and their associated reverse osmosis water purification systems require

significant maintenance. Impurities in the water used in an ultrasonic system can be deposited into the computer equipment itself if proper procedures are not followed.

The latest steam canister designs are capable of regulating the amount of steam they produce to the exact amount needed and also have the ability to compensate for electrode fouling. This results in better humidity control, lower electrical consumption and fewer maintenance requirements. A summary of the relative costs associated with the three types of humidifiers is shown in **Table 3**.

**Table 3**

*Characteristics of humidifiers*

Type of humidifier	Capital cost	Operational cost	Maintenance cost
Steam canister	Low	High	Low
Infrared	Low	High	Low
Ultrasonic	High	Low	High

Two factors affecting the amount of water a cooling system removes are the temperature of the air returning to the cooling system and the engineering of the cooling system itself. Air management practices must minimize the mixing of hot and cold air within the IT environment and guard against cool air bypassing IT equipment altogether. When previously cooled “bypass” air re-enters a CRAC or CRAH it’s cooled to a lower than desirable temperature. This means the air progressively loses more water vapor to excess condensation as it repeatedly passes through the cooling coil. This is an undesirable situation for several reasons:

- The unit uses a larger portion of its available cooling capacity to remove extra water when that same capacity could be otherwise used to cool computer equipment.
- Humidifiers are also forced to operate at full capacity, wasting electricity.
- Cool air bypassed back into the computer room air conditioner or air handler can “trick” the unit into reducing its cooling capability because it senses that the room’s cooling needs are met.

All of these effects waste energy and risk thermal damage to computer equipment due to a lack of cool airflow. In this situation lowering the air conditioner’s temperature set point will have no effect on room temperature and may even increase the rate of condensation at the cooling coil. This damaging sequence of events can be avoided by introducing proper air management practices into the IT environment. See White Paper 55, *Air Distribution Architecture Options for Mission Critical Facilities* for more information on this topic.

 Related resource  
**White Paper 55**

*Air Distribution Architecture  
Options for Mission Critical  
Facilities*

The engineering of a precision cooling unit itself also determines the amount of condensation during normal operation. The amount of moisture removed by the air conditioner is dependent on the size of its cooling coil, the cooling coil temperature, and the velocity in which air is forced through it. A measure of a precision cooling unit’s capability to remove heat without removing moisture is the unit’s *sensible heat ratio*. A value of “1” indicates no moisture is removed from the air via condensation. This number (or the information to calculate it) is published in the manufacturer’s technical data for their cooling systems. The sensible heat ratio is an important indicator of the efficiency of the cooling system and is usually considered in the specification process. Sensible heat ratio values closest to “1” are best for IT environments.

Computer room air conditioners are also capable of increasing their rate of condensation to purposely dehumidify the IT environment. This is achieved either by lowering the cooling coil



temperature, slowing the airflow through the cooling coil, or reducing the size of the cooling coil. The air exiting the cooling coil under these conditions is colder than normal and has lost more moisture to condensation.

Computer room air conditioners use additional coils (if installed) heated by electricity, steam, hot water or hot gas (hot refrigerant from the compressor) to *reheat* the exiting air stream back to the normal exit temperature. This reheat process further dehumidifies the air. Some systems assist the reheat process by mixing smaller amounts of warm air from the IT environment with the cold dehumidified air before it exits the precision cooling system. In most climates dedicated dehumidification happens only occasionally and is often associated with periods of rainy weather. Frequent or continuous dedicated dehumidification is usually the result of severe infiltration (in humid climates) or over-humidification occurring in another computer room air conditioner in the room.

### Dew point control of IT environment humidity

Controlling IT environment humidity by maintaining dew point temperature is more cost effective than maintaining relative humidity. As air increases in temperature it requires more moisture be added to maintain the same relative humidity. For example, air at 90°F (32.2 °C) and 50% RH contains 96% more water (by weight) than air at 70°F (21.1 °C) and 50% RH (at sea level). If the air returning to two CRAC units (with the same RH setting) in the same room is at different temperatures, the higher temperature return air will have more water added to it by the humidifier in the CRAC unit than the lower temperature return air will.

When a room contains several computer room air conditioners set to maintain the same RH the unequal addition of moisture among them can eventually trigger one or more of the units to go into dehumidification mode. The other air conditioners will detect the resulting drop in humidity and will increase their own humidification to compensate. In an unmonitored room containing several CRAC units, it is possible to have half the room's cooling units adding humidity while the other half work to reduce it. This condition is known as *demand fighting* and is one of the primary causes of excessive energy consumption in IT environments.

Dew point control of IT environment humidity greatly reduces the frequency of demand fighting. This is due to the fact that as air increases in temperature in an IT environment its dew point stays the same. For example, air at 90°F (32.2 °C) exiting a piece of computer equipment has exactly the same dew point as the 70°F (21.1 °C) air entering the computer. Relative humidity and measured air temperature are always related for any specific dew point temperature. When several CRAC or CRAH units are set to maintain humidity via dew point, large differences in return air temperature will not drive excessive humidification or dehumidification in different units. All cooling units simply maintain humidity based on the actual amount of water required in each pound of air that passes through the unit. Elimination of demand fighting in data centers can significantly increase the efficiency of the cooling system.

Setting humidity higher than actually required by IT equipment lowers the heat removal capability of the unit and wastes electrical energy. Humidifiers must add unnecessary water to the air flowing through the CRAC or CRAH unit. This can waste thousands of gallons / liters of water per year in a typical data center. Furthermore, steam canister and infrared humidifiers are a significant source of heat that must also be removed by the CRAC unit and consequently further detracts from its capacity. This situation is made even worse when significant hot and cold air mixing occurs in the data center because the lower temperature air returning to the CRAC unit loses more moisture in the cooling process than warmer, unmixed air would. Therefore it is essential not to operate a data center at higher humidity levels than the minimum recommended level.

Real-world  
examples of cost  
minimization

Some data centers have high velocity paper or forms printers. These printers can generate significant static electrical charge. To control static discharge relative humidity levels of about 50% or higher are sometimes specified. However, for data centers without large high-speed forms printers a relative humidity of 40% will control static charge. Operating a data center at 40% minimum relative humidity instead of 45% or 50% can save significant amounts of water and energy. Operation of the system within lower limits of the relative humidity design parameters should be considered for efficiency and cost savings. A slight change in set point toward the lower end of the recommended range can have a dramatic effect on the heat removal capacity and reduction in humidifier run time.

The example illustrated in **Table 4** provides an analysis of a single Glycol-cooled computer room air conditioner with 50kW of IT equipment heat removal capacity was conducted (see **Appendix** for list of specifications and assumptions).

**Table 4**

*Humidification cost savings example at lower set point*

<b>Temperature 72°F (22.2°C)</b>		
Relative humidity set point	50%	45%
<b>Cooling capacities –kW (Btu/hr)</b>		
Total cooling capacity	48.6 (166,000)	49.9 (170,000)
Total sensible (temperature change) capacity	45.3 (155,000)	49.9 (170,000)
<b>Humidification requirement</b>		
Total latent (moisture removed) capacity	3.3 (11,000)	0.0 (0,000)
Lbs./hr. humidification required – btu/1074 (kW/.3148)	10.24	0
Humidifier runtime	100.0%	0.0%
kW required for humidification	3.2	0
Annual cost of humidification (cost per kW x 8760 x kW required)	\$2,242.56	\$0.00

This example supports the assumption that proper construction techniques which minimize humidity infiltration combined with proper air and humidity management practices can amount to significant reductions in operating capital. The 45% column in **Table 4** shows the entire capacity of the computer room air conditioner being devoted to cooling IT equipment. No moisture is being unnecessarily removed from the air so no moisture has to be added back in. This configuration simultaneously provides the IT and facilities professional with maximum heat removal from IT equipment and minimum operational cost.

## Conclusion

The amount of moisture contained in the air used to cool IT equipment can help ensure its availability or lead directly to its failure. An interdependent relationship exists between humidity management and cooling air management procedures. Dehumidification of air always reduces IT heat removal capability. Humidification of air always costs money. Both should be used only when absolutely necessary. Effective humidity control in the IT environment is most effectively applied as part of an overall IT environment strategy involving optimization of air management, IT load planning, and infiltration minimization.



### About the author

**Tony Evans** is an engineer with Schneider Electric in West Kingston, RI. He has 14 years of experience in power and cooling system design and is a member of ASHRAE Technical Committee 9.9 (Mission Critical Facilities, Technology Spaces, & Electronic Equipment).



## Resources

Click on icon to link to resource



### Improving Cooling Performance Using Blanking Panels

White Paper 44



### Air Distribution Architecture Options for Mission Critical Facilities

White Paper 55



### White Paper Library

[whitepapers.apc.com](http://whitepapers.apc.com)



### TradeOff Tools™

[tools.apc.com](http://tools.apc.com)



## Contact us

For feedback and comments about the content of this white paper:

Data Center Science Center  
[DCSC@Schneider-Electric.com](mailto:DCSC@Schneider-Electric.com)

If you are a customer and have questions specific to your data center project:

Contact your **Schneider Electric** representative

## Appendix: Assumptions and specifications for Table 4

Both scenarios in the humidification cost savings example in **Table 4** are based on the following assumptions:

- 50kW of electrical IT loads which results in approximately 50kW of heat dissipation
- Air temperature returning to CRAC inlet is 72°F (22.2°C)
- Based on 1 year operation (7x24) which equates to 8,760 hours
- CRAC unit volumetric flow of 9,000 CFM (4,245 L/s)
- Ventilation is required but for simplification it was assumed that the data center is completely sealed - no infiltration / ventilation
- Cost per kW / hr. was assumed to be \$0.08 (U.S.)
- CRAC unit specifications based on an APC FM50:
- Standard downflow
- Glycol cooled unit (no multi-cool or economizer)
- Electrode steam generating humidifier (Plastic canister type with automatic water level adjustment based on water conductivity)
- Humidifier capacity is 10 lbs (4.5 kg) / hr.
- Humidifier electrical consumption is 3.2kW
- Voltage is 208